

RoHS Compliant

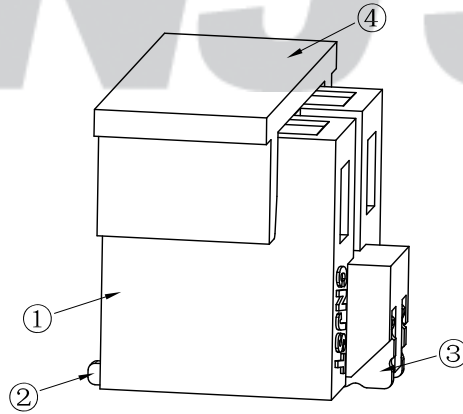
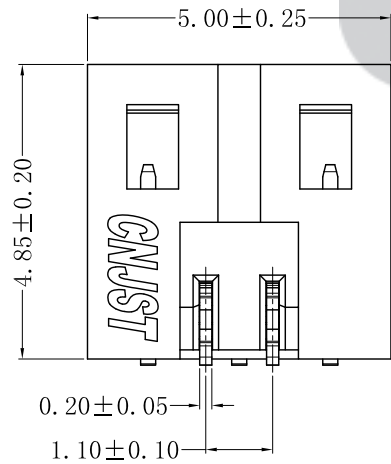
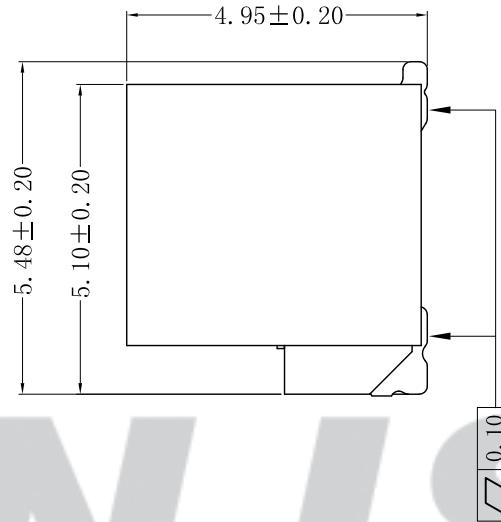
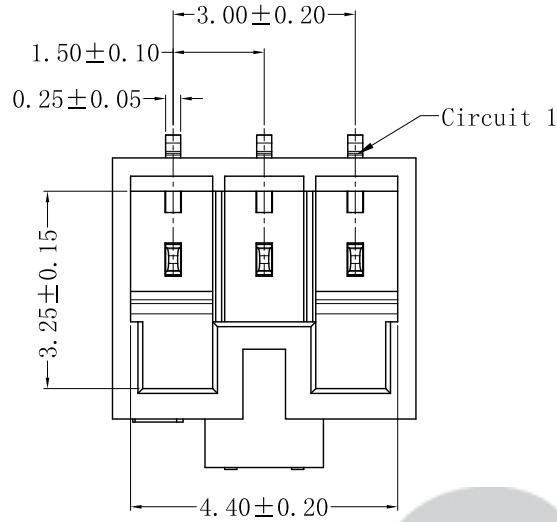

Apply to Reel

SPECIFICATION

- 1 Contact resistance: $\leq 20m\Omega$
- 2 Insulation resistance: $\geq 1000M\Omega$
- 3 Rated voltage: 250 V AC DC
- 4 Rated current: 1.0 A AC DC
- 5 Withstand Voltage: 1500 V AC/minute
- 6 Temperature Range: $-25^{\circ}C \sim +85^{\circ}C$

ORDER INFORMATION:

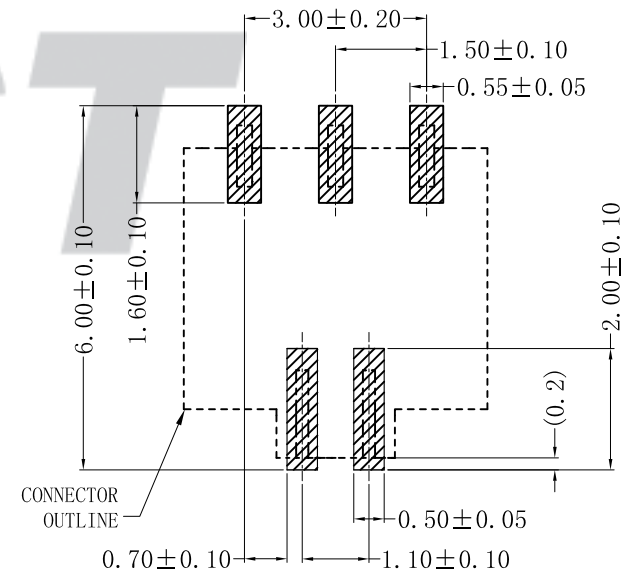
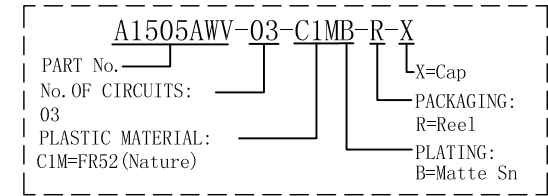

SUGGESTED PCB LAYOUT
(COMPONENT SIDE)

专利产品

④	Cap	1	LCP	Nature
③	Solder Tab	2	Phosphor Bronze	Matte Sn
②	Contacts	3	Phosphor Bronze	Matte Sn
①	Insulator	1	FR52 (UL94V-0)	Nature
NO.	DESCRIPTION	QTY	MATERIAL	PLATING/COLOR

Tolerance	
X.X	± 0.30
X.XX	± 0.20
X.XXX	± 0.10
Angle	$\pm 3.0^{\circ}$
UNIT: mm	

CNJST 捷仕泰企业

Model No.: A1505AWV-03-C1MB-R-X

Model Name: 1.50mm PITCH 180° WAFER-SMT TYPE

SCALE: FULL REVISION: C/0

Drawn: 王丽君 2022.12.16
Checked: 吴丹平
Approved: 林旭芝
DWG NO. CNJST/GCCP-0703

C/O	2020.05.21	统一标准 更新模板	王丽君
REV.	DATE	DESCRIPTION	APPD.