

RoHS Compliant

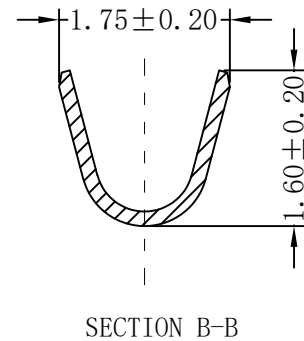
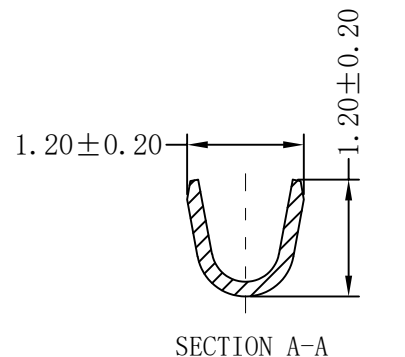
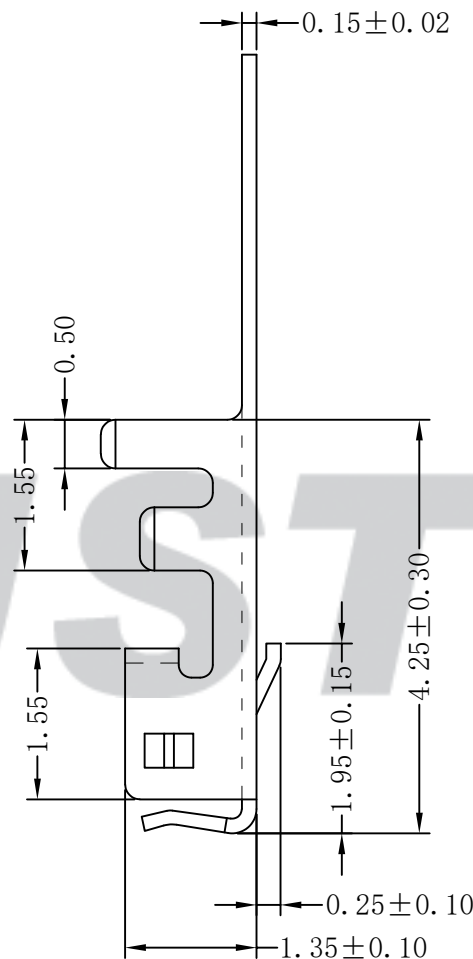
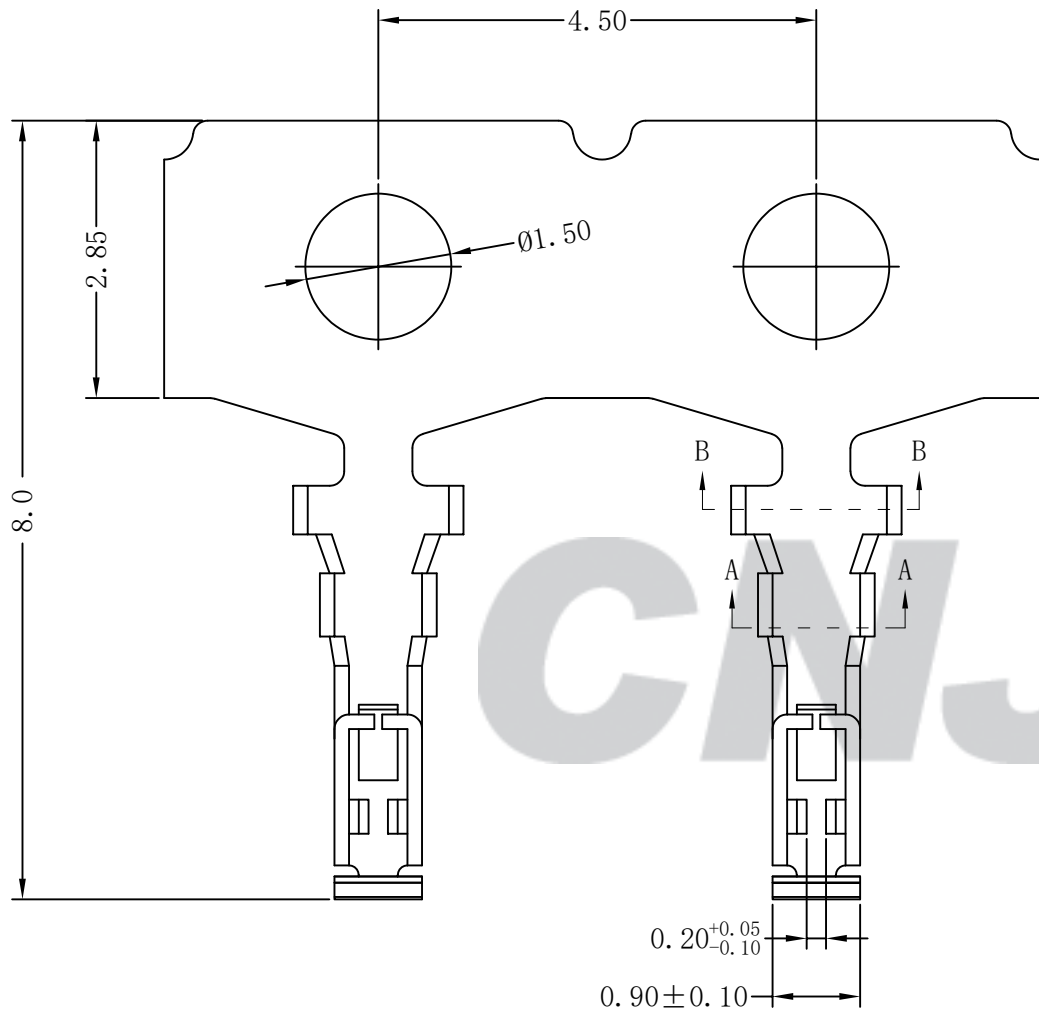

Tolerance X.X ±0.30 X.XX ±0.20 X.XXX ±0.10 Angle ±3.0°	CNJST 捷仕泰企业		Drawn: 王程伟 2022.12.29
	Model No.: A1504T-PA-Z		Checked: 吴丹平
	Model Name: 1.50mm PITCH CRIMP TERMINAL		Approved: 林旭芝
UNIT: mm	⊕	SCALE: FULL	REVISION: C/0
			DWG NO. CNJST/GCCP-0078

C/0	2022.12.29	模版更新	王程伟	AWG #26~#30		10,000Pcs	Phosphor Bronze	Tin-plated
REV.	DATE	DESCRIPTION	APPD.	Wire Range	Insulation O.D.	QTY/Reel	Material	Plating