

RoHS Compliant

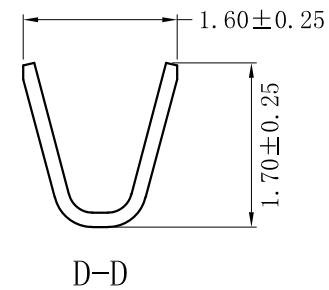
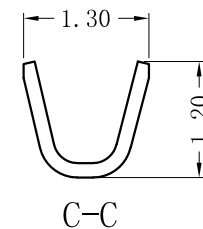
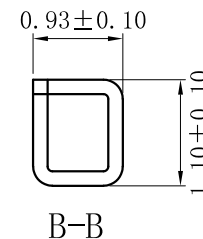
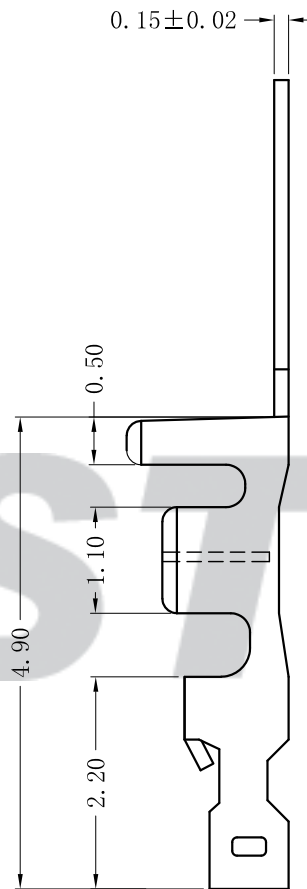
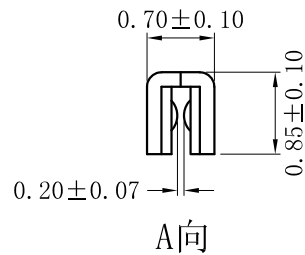
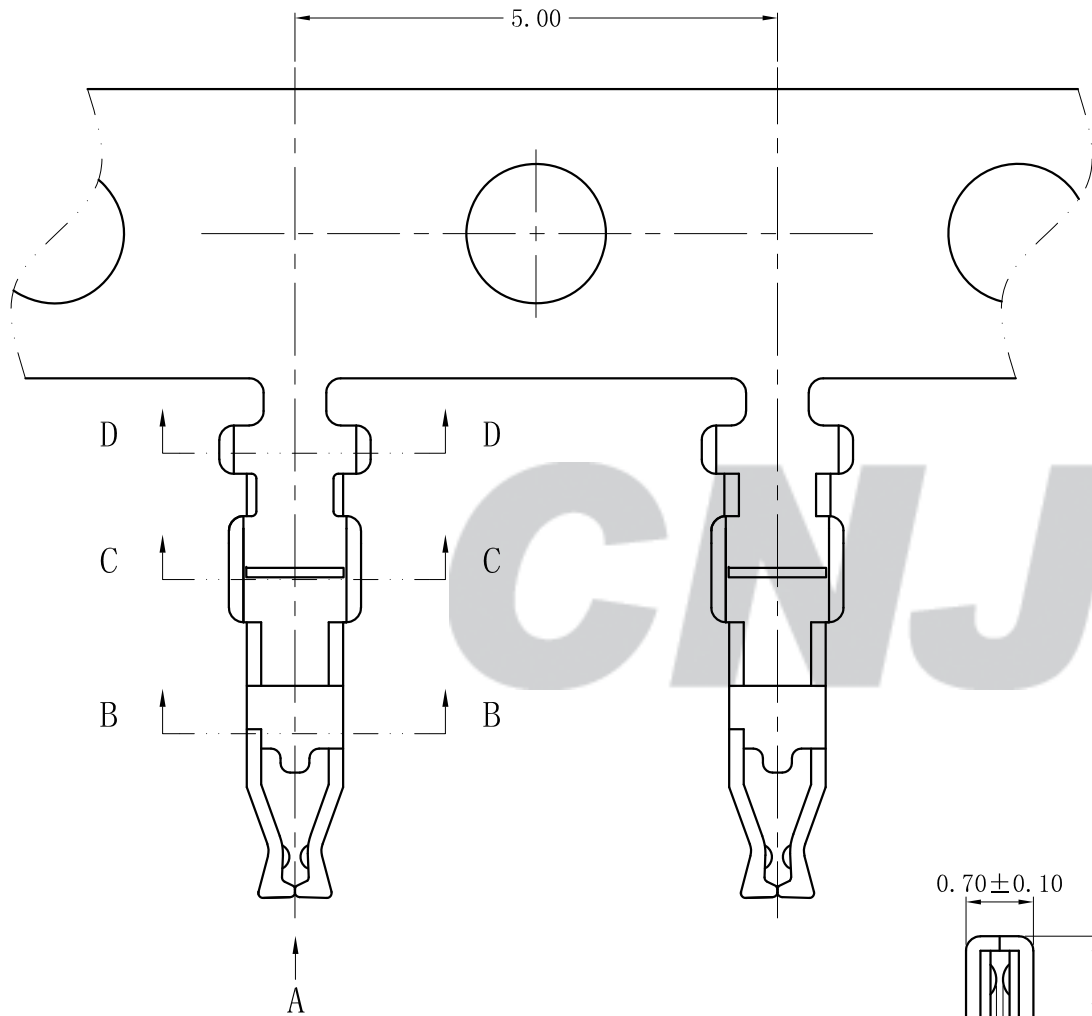
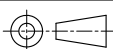

Tolerance X.X ±0.30 X.XX ±0.20 X.XXX ±0.10 Angle ±3.0°	CNJST 捷仕泰企业		Drawn: 王丽君 2022.12.28
	Model No.: A1252T-P*-Z		Checked: 吴丹平
UNIT: mm	Model Name: 1.25mm PITCH CRIMP TERMINAL		Approved: 林旭芝
		SCALE: FULL	REVISION: C/0
			DWG NO. CNJST/GCDZ-0003

C/0	2022.12.28	更新模板	王丽君	A1252T-PC-Z	AWG #28~#32	0.90mm(max)	10,000Pcs	Phosphor Bronze	Gold-plated
REV.	DATE	DESCRIPTION	APPD.	Part No	Wire Range	Insulation O.D.	QTY/Reel	Material	Plating