

RoHS Compliant

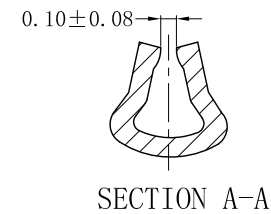

SECTION A-A

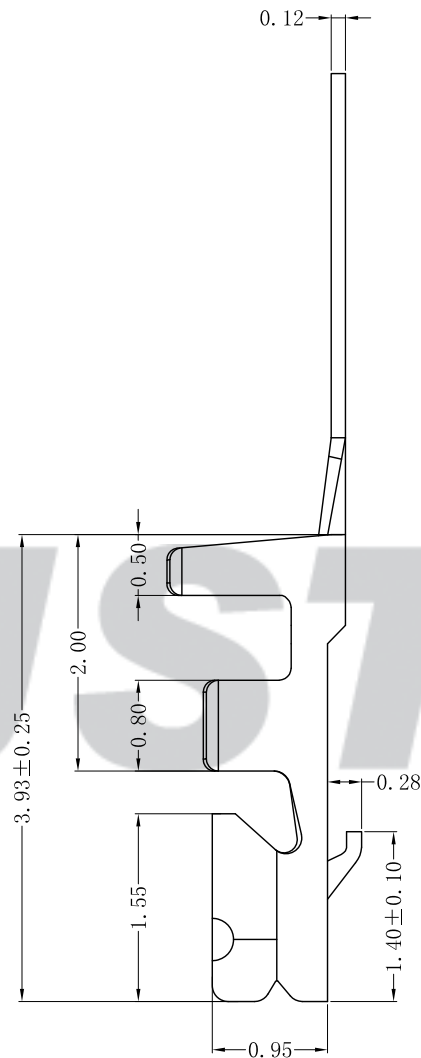
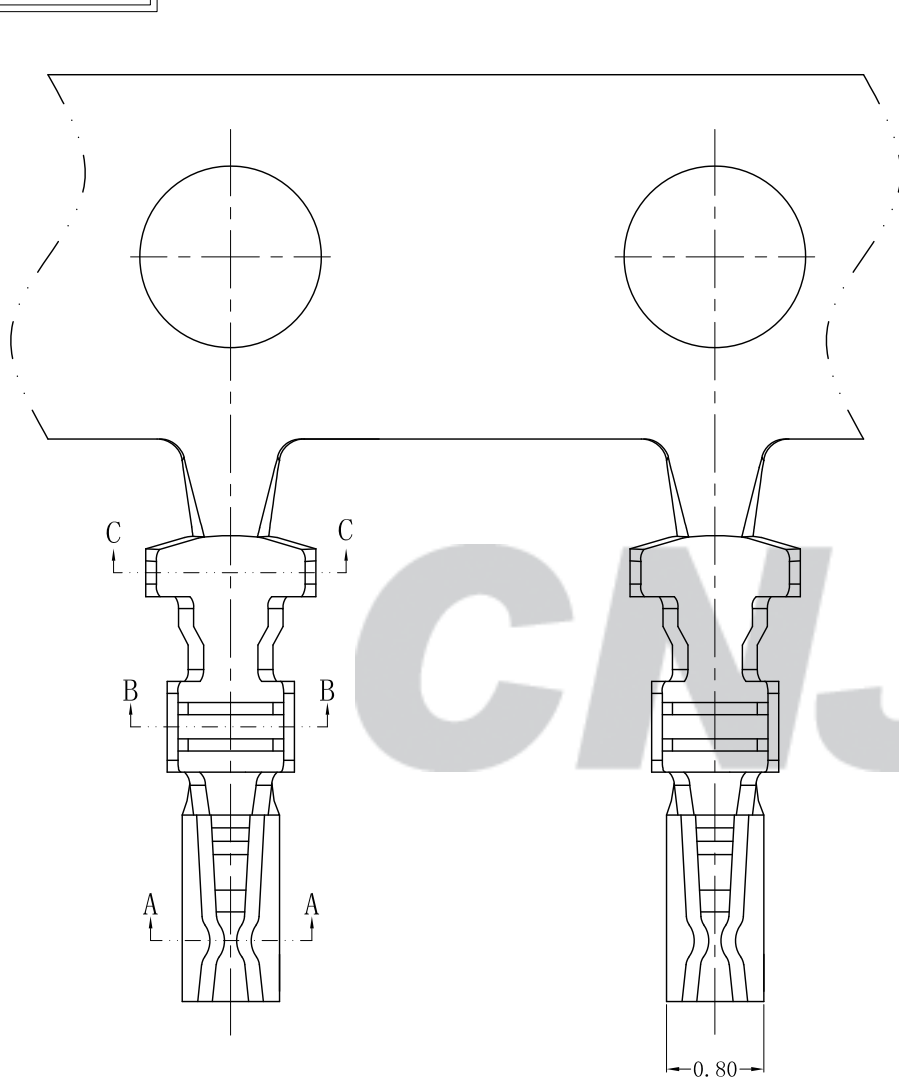
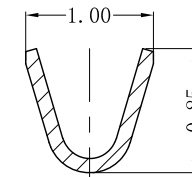

SECTION B-B

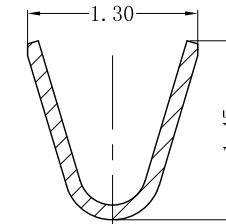

SECTION C-C

Tolerance
 X.X ±0.30
 X.XX ±0.20
 X.XXX ±0.10
 Angle ±3.0°

CNJST 捷仕泰企业

Drawn: 王丽君 2022.07.14

Model No.: A1020T-PA-Z

Checked: 吴丹平

Model Name: 1.00mm PITCH CRIMP TERMINAL

Approved: 林旭芝

REV.	DATE	DESCRIPTION	APPD.	Wire Range	Insulation O.D.	QTY/Reel	Material	Plating
C/1	2022.07.14	更新模板	王丽君					
C/0	2021.05.12	NEW RELEASE	王程伟	AWG #28~#32	0.80mm (Max)	/	Phosphor Bronze	Tin-plated

UNIT: mm

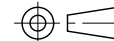

SCALE: FULL

REVISION: C/1

DWG NO. CNJST/GCDZ-0763